

Guide Values – for tightening torques

The torques given here are standard values, valid for metric standard threads (ISO threads) according to DIN 13 and head rest dimensions according to DIN 912, 931, 934, 6912, 7984, 7990. They result in an approx. 90% utilisation of the screw yield point.

It should be noted that the coefficient of friction, depending on the surface condition of the screws and nuts as well as the lubrication condition of the thread, has an influence on the stated values and may have to be corrected.

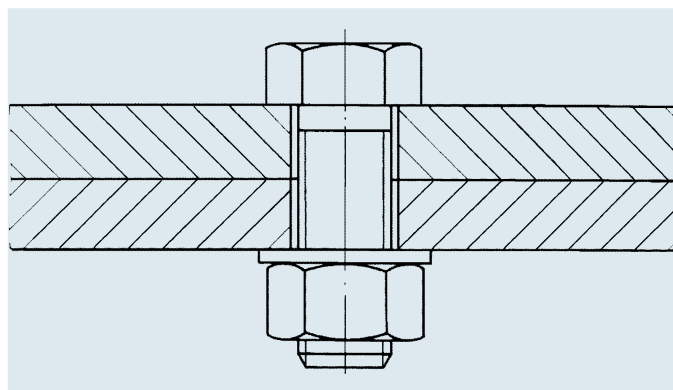

Nominal Size #	A/F internal mm	A/F external mm	Friction coefficient μ	Tightening torque M_A for screw strength class according to DIN 267, ISO 898/1					
				3.6	5.6	6.9	8.8	10.9	12.9
				N-m	N-m	N-m	N-m	N-m	N-m
M2	–	4	0.10	–	–	0.26	0.32	0.47	0.55
			0.14	–	–	0.31	0.38	0.56	0.65
M3	–	5,5	0.10	0.30	0.51	0.81	1.1	1.5	1.8
			0.14	0.37	0.62	0.99	1.3	1.9	2.2
M4	3	7	0.10	0.70	1.2	1.9	2.4	3.3	4.0
			0.14	0.85	1.4	2.3	2.9	4.1	4.9
M5	4	8-9	0.10	1.4	2.3	3.6	4.9	7.0	8.0
			0.14	1.7	2.8	4.5	6.0	8.5	10
M6	5	10	0.10	2.4	3.9	6.3	8.0	12	14
			0.14	2.9	4.8	7.7	10	14	17
M8	6	13-14	0.10	5.7	9.5	15	20	28	34
			0.14	7.0	12	19	25	35	41
M10	8	15-17	0.10	11	19	30	40	56	67
			0.14	14	23	37	49	69	83
M12	10	19-21	0.10	20	33	52	69	98	115
			0.14	24	40	65	86	120	145
M14	12	22-23	0.10	31	52	83	110	155	185
			0.14	39	64	105	135	190	230
M16	14	24-26	0.10	48	79	125	170	240	285
			0.14	59	98	155	210	295	355
M18	14	27	0.10	66	110	175	235	330	395
			0.14	81	135	215	290	405	485
M20	17	30	0.10	92	155	245	330	465	560
			0.14	115	190	305	410	580	690
M22	17	34	0.10	125	205	330	445	620	750
			0.14	165	260	415	550	780	930
M24	19	36	0.10	160	265	425	570	800	960
			0.14	200	330	530	710	1000	1200
M27	–	41	0.10	235	390	630	840	1200	1400
			0.14	295	490	780	1050	1500	1800
M30	–	46	0.10	320	530	850	1150	1600	1950
			0.14	395	660	1050	1450	2000	2400
M33	–	50	0.10	430	720	1150	1550	2150	2600
			0.14	540	900	1450	1900	2700	3250
M36	–	55	0.10	550	920	1500	1950	2750	3300
			0.14	690	1150	1850	2450	3450	4150



Further information available 24 / 7 on our website.