

## Preset Torque Screwdriver – P-2H

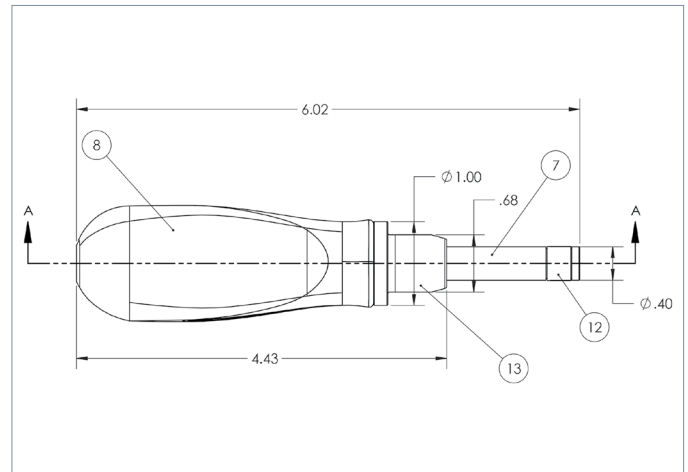

### Introducing the New P-series Torque Drivers

SR: "We know a little bit about torque screwdrivers. After all, we invented them. That was more than seventy years ago! Back then, we made the best torque screwdriver on the planet. More than seventy years later, that hasn't changed."

The all-new P Series torque drivers incorporate the heritage of SR's legendary durability along with great accuracy and repeatability. It uses the same clutch and spring from the PM Series torque screwdrivers. That means you get the same smooth rotation, great accuracy, unparalleled repeatability, and legendary durability.

The new P Series comfort grip is ergonomically friendly. Not only is it very comfortable in your hand, but it also gives you greater purchase in turning the driver to reach target torque.

The P Series drivers only need 18 degrees of rotation to reach target torque. Other brands require 36 degrees or even 45 degrees of rotation. Some brands even need 90 degrees of rotation to achieve target torque.

Once you achieve target torque with the P Series, the handle spins and doesn't apply torque. You can't over-torque a fastener with this tool.

The P Series driver is the type of tool that gives the operator confidence that the job will be done quickly and done right. That is why so many people around the world trust Sturtevant Richmond tools.

- ▶ Torque can be set to any unit of measure.
- ▶ Extremely smooth rotation requires only 18 degrees of turn to reach the target torque.
- ▶ Bi-directional versatility – preset same value for both CW and CCW measurement.
- ▶ Anti-backlash design for ergonomic comfort.
- ▶ The clutch releases automatically.
- ▶ The new grip is very comfortable in your hand; it gives operators greater purchase in turning the driver.
- ▶ 1/4" Female Hex drive uses power bits and insert bits.
- ▶ Accuracy of  $\pm 6\%$  or better of indicated value from 20% to 100% of the rated capacity.
- ▶ Meets or exceeds **EN ISO 6789:2017** and **ASME B107.300-2010**.

*The comfort grip makes reaching 40 inch-pounds of torque easy. Some prefer the use of the steel sliding T Handle. Either way, you'll love the P Series.*

#### INFO

*Can be ordered pre-set from the factory with a calibration certificate from SR's ISO/IEC 17025 accredited calibration laboratory.*

### P-2H

Model	Item No.	Torque Range*				L mm	Ø G mm	Weight kg	Hex inch
		cN-m	N-m	ozf-in	lbf-in				
P6-2H	R810501	14 - 70	0.14 - 0.7	20 - 100	1.2 - 6.2	n.a.	n.a.	0.2	¼
P20-2H	R810502	45 - 225	0.45 - 2.3	48 - 240	4.0 - 20	n.a.	n.a.	0.2	¼
P40-2H	R810503	90 - 450	0.9 - 4.5	115 - 575	8.0 - 40	153	39.9	0.2	¼



Further  
info on our  
website.  
24/7

\* Table showing specifications by manufacturer. Usage in moderate performance range (approx. 1/3 to 4/5 of rated capacity) is recommended. If you regularly worked close to the limit of load (maximum capacity), a larger model or tool might be more advisable.

TEL: +49(0)40 303 989 100 • FAX: +49(0)40 303 989 101 • MAIL: info@zemo-tools.de