

Parts for Liner Case

No.	Name of parts	Per set	parts No.
L	Liner Case Assy.	1Set	0446 0422 0099
L1	Liner Case	1	0446 0422 0000
L2	O-Ring 1.78×33.05×36.61	1	9011 2002 0000
L3	Liner Cap	1	0368 0423 0000
L4	Liner Upper Plate	1	0181 0424 0000
L5	O-Ring 1.78×29.87×33.43	1	9011 2003 0000
L6	Liner Assy.	1Set	0181 0425 0099
	(a) Liner	1	※ ↑
	(b) Pin FF AA3×4.5	4	8052 3004 0000
L7	Relief Valve	1	0446 0245 0000
L8	Pin 1.5×4	1	8051 1314 0000
L9	Liner Shaft	1	0181 0796 0100
L10	Blade	2	0181 0719 0100
L11	Spring 3.4×28	2	8020 1346 0000
L12	Liner Lower Plate Assy.	1Set	0181 0426 0199
	(a) Liner Lower Plate	1	0181 0426 0100
	(b) Pin AA3×4.5	1	8052 3004 0000
L13	Adjust Bolt	1	0181 0522 0000
L14	O-Ring N2	1	9010 4001 0000
L15	Back-up Ring N2	1	9090 2001 0000
L16	Nylon Bushing	1	0181 0431 0000
L17	Oil Plug	2	0181 0010 0000
L18	O-Ring N2	2	9010 4001 0000
L19	O-Ring P12	1	9011 7001 0000
L20	Back-up Ring 12×16×0.8	1	9090 1010 0000
1	Washer 12×15.8×4.8	1	8040 1165 0000
★2	Washer 11.5×16×0.2	1	8041 5046 0000
★3	Washer 11.5×16×0.3	1	8041 5026 0000
★4	Washer 11.5×16×0.4	1	8041 5065 0000
★5	Washer 11.5×16×0.5	1	8041 5022 0000

The part "※" can not be supplied individually.
So please order it as a unit of assembly shown by
arrow mark (↑).
☆marked parts ; one of them is used.

Battery System Wrench with built-in angle sensor

MODELS (YES.No.)	TOOL No.
YS-e900 (00)	0446 0000 0000

Exploded View of Liner Case & Hammer Case

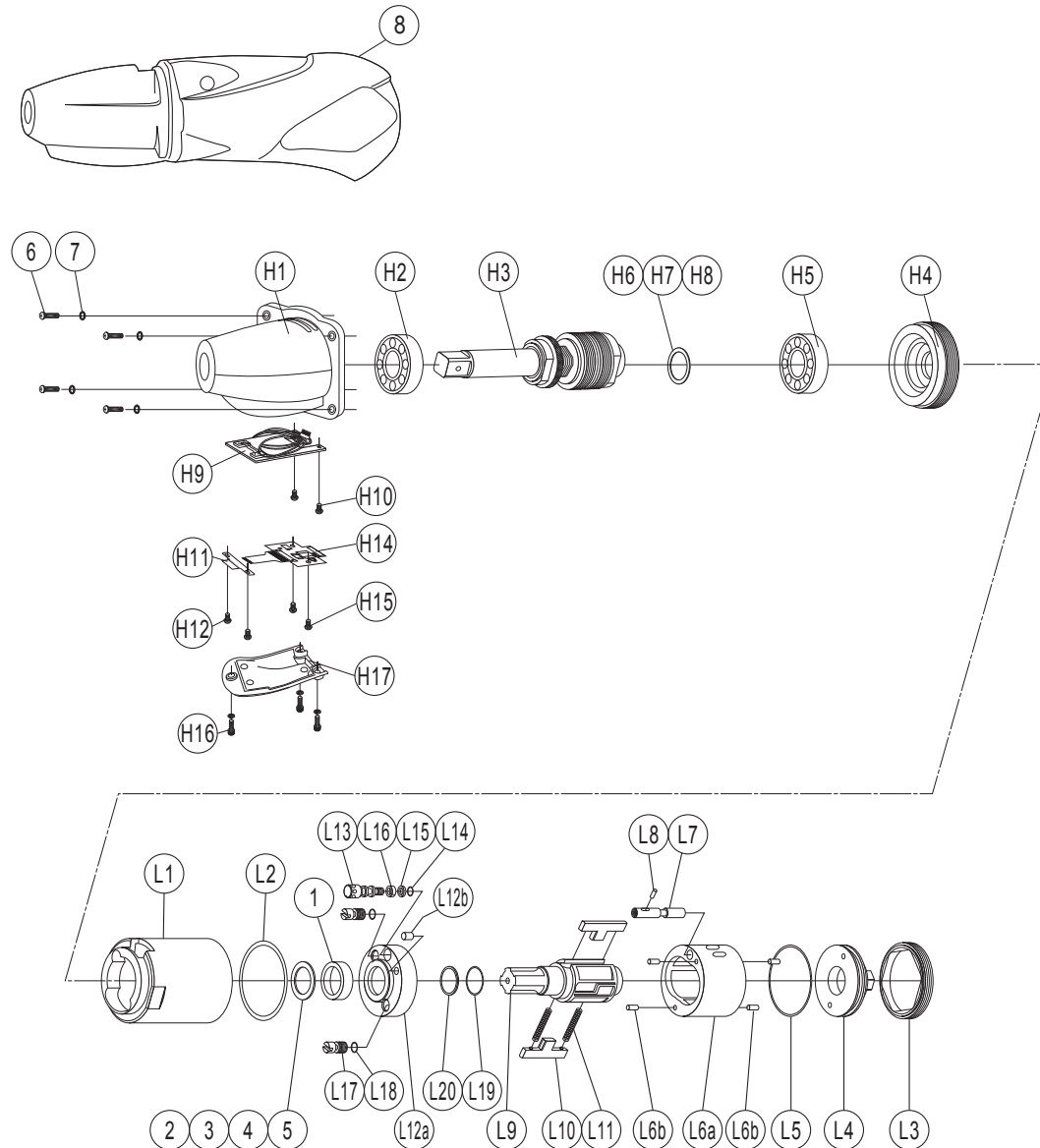

Parts for Hammer Case

No.	Name of parts	Per set	parts No.
H	Hammer Case Assy.	1Set	0446 0401 0099
H1	Hammer Case	1	0446 0401 0000
H2	Ball Bearing 6801ZZ	1	9100 5028 0000
H3	Main Shaft Assy.	1Set	0446 0614 0099
H4	Bearing Case	1	0446 0650 0000
H5	Ball Bearing 6802ZZ	1	9100 5037 0000
★H6	ST-Packing 20×23.6×0.2	1	8011 1167 0000
★H7	ST-Packing 20×23.6×0.3	1	8011 1168 0000
★H8	ST-Packing 20×23.6×0.4	1	8011 1169 0000
H9	Wire Circuit Board	1	0446 1611 0000
H10	Screw M3x8	2	9440 2029 0000
H11	Sensor Base Assy.	1Set	0446 0345 0099
H12	Wire Circuit Board	2	9440 2029 0000
★H13	ST-Packing 3.4×6.1×0.1	2	8011 1166 0000
H14	Torque Circuit Board Assy.	1Set	0446 1607 0399
H15	Screw M3x6 P=0.5	2	9400 2014 0000
H16	Cover Plate	1	0446 0014 0000
H17	Screw M3x10	3	9440 2013 0000
6	Hexagon Socket Bolt M4×14	4	8070 3008 0000
7	Spring Washer M4	4	9200 3012 0000
8	Optional Accessories		
9	Protector	1	0446 0029 0000
	TF Pin	1	8051 6001 0000

The part "※" can not be supplied individually.
So please order it as a unit of assembly shown by
arrow mark (↑).
☆marked parts ; one of them is used.

Parts for Motor Case

No.	Name of parts	Per set	parts No.
M	Motor Case Assy.	1Set	0446 0011 00 99
M1	Motor Case (A)	1	0446 0011 00 01
M2	Motor Case (B)	1	0446 0011 00 02
M3	Motor Case (C)	1	0446 0011 00 03
M4	Tapping Screw M3x16	7	9540 1018 00 00
M5	Motor Assy.	1Set	0446 0330 00 99
M6	Fan D03X-05TM11(CX)	1	0446 1556 00 00
M7	Cross Recessed Screw M3×15	2	9410 2047 00 00
M8	Power Circuit Board Assy.	1Set	0446 0195 00 99
M9	Head Screw	3	9410 4002 00 00
M10	Harness (A)	1	0446 0208 00 01
M11	Controll Circuit Board Assy.	1Set	0446 1608 02 99
M12	O-Ring (S6)	2	9010 4026 00 00
M13	Harness (B)	1	0446 0208 00 02
M14	Wireless Circuit Board Assy.	1Set	0446 1533 00 99
M15	Lamp Holder	1	0446 0959 00 00
M16	Throttle Knob Assy.	1Set	0446 0153 00 99
M17	Spring 7.5×27	1	8020 1428 00 00
M18	Reverse Lever Assy.	1Set	0446 0007 00 99
M19	Reverse Lever Spring	1	0446 1615 00 00
M20	Tapping Screw M2.6x5	1	9540 1019 00 00
M21	Binding Band (CV-70N)	5	9790 1008 00 00
Optional Accessories			
10	Protector (for BPL-1820)	1	0446 0029 0001
11	Battery Pack BPL-1820	1	0446 1521 0000
	Battery Charger BC0075G	1	0446 1606 0000
	Power Cord 1.5M (Domestic)	1	8521 0008 0000
	Power Cord 1.5M (R. Pin for Europe)	1	8521 0009 0000
	Power Cord 1.5M <VM0718-VM0719>	1	8521 0029 0000
	Power Cord 1.5M <VM0228A-VM0296> for US	1	8521 0032 0000
	Power Cord 1.5M <VM0773-VM0776> for India	1	8521 0033 0000

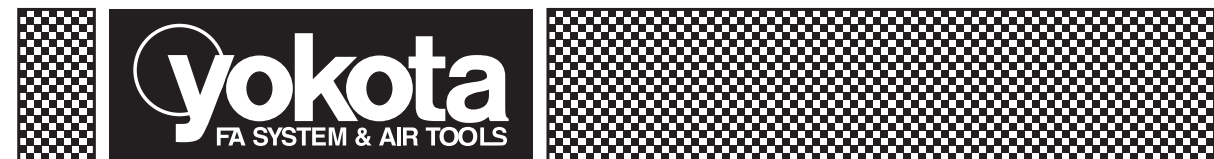

Battery System Wrench with built-in angle sensor

MODELS (YES.No.)	TOOL No.
YS-e900 (00)	0446 0000 0000

Exploded View of Motor Case

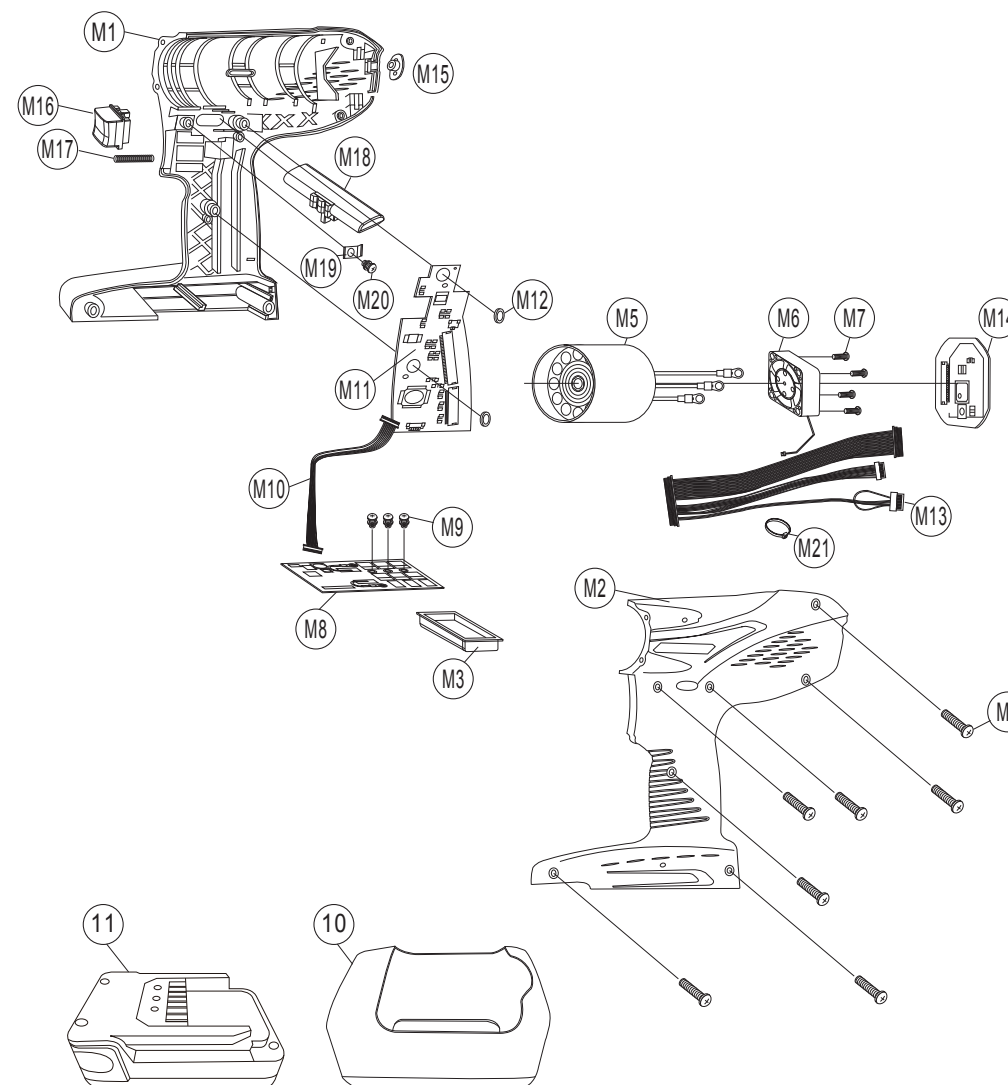

YOKOTA INDUSTRIAL CO.,LTD.