

816799 - THIS PIN IS FORMED OVER CUSTOMER MUST GRIND OFF FORMED END & INSTALL THIS PIN FORMING THE HEAD OVER THE RETAINING RING AS SHOWN.

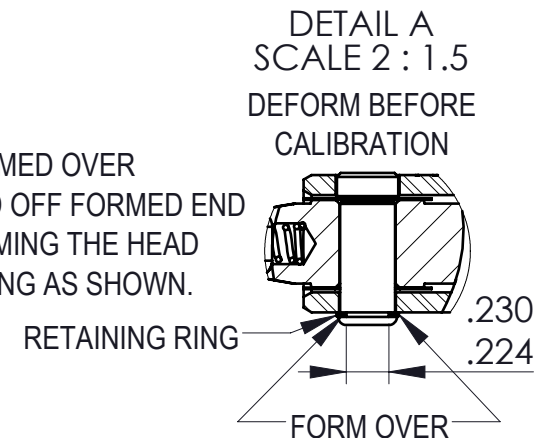

857451 - INSTRUCTIONS
820050 - CARTON

LEGEND: () = QUANTITY/TOOL
* = QUANTITY/MULTI-PAK